

MAXIM

MAX3869 Evaluation Kit

General Description

The MAX3869 evaluation kit (EV kit) is an assembled demonstration board that provides optical or electrical evaluation of the MAX3869.

The EV kit is composed of two independent sections on the PC board. The output of the electrical evaluation section is interfaced to an SMA connector, which can be connected to a 50Ω terminated oscilloscope. The output of the optical evaluation section is configured for attachment to a laser/monitor diode.

Features

- ◆ Fully Assembled and Tested
- ◆ +3.3V to +5.0V Operation
- ◆ Input Termination Provided On-Board
- ◆ Independent Electrical Monitoring of Modulation and Bias Currents

Ordering Information

| PART | TEMP. RANGE | IC PACKAGE |
|--------------|----------------|-------------|
| MAX3869EVKIT | -40°C to +85°C | 32 TQFP-EP* |

*EP = Exposed paddle

Electrical Component List

| DESIGNATION | QTY | DESCRIPTION |
|-------------------------|-----|---|
| C24, C25, C28, C32 | 4 | 0.01μF ±10% ceramic capacitors (0402) |
| C26, C27, C29, C30, C33 | 5 | 0.1μF ±10% ceramic capacitors (0603) |
| C37, C39 | 2 | 0.056μF ±10% ceramic capacitors (0603) |
| C40 | 1 | 10μF ±20% tantalum (16V) capacitor AVX TAJC106M016 |
| C41, C45 | 2 | 0.01μF ±10% ceramic capacitors (0603) |
| C42 | 1 | 0.22μF ±10% ceramic capacitor (0805) |
| C43 | 1 | 1000pF ±10% ceramic capacitor (0402) |
| C44 | 1 | Do not install |
| D3 | 1 | LED, Digi-Key P363-ND |
| J5–J9 | 5 | SMA edge-mount connectors EF Johnson 142-0701-801 or Digi-Key J502-ND |
| JU4, JU5 | 2 | Shunts Digi-Key S9000-ND |
| JU4, JU5 | 2 | 2-pin headers (0.1in center) Digi-Key S1012-36-ND |
| L7, L13 | 2 | 1kΩ ferrite beads (0805) Murata BLM21A102S |
| L9 | 1 | 1.2μH inductor Coilcraft 1008LS-122XKBC |
| L10, L11 | 2 | 600Ω ferrite beads (0603) Murata BLM11A601S |
| Q2 | 1 | PNP transistor (SOT23) Zetex FM591A ("91A" marking) |

| DESIGNATION | QTY | DESCRIPTION |
|--|-----|--|
| R4, R17 | 2 | Do not install |
| R5, R22, R47 | 3 | 1.5kΩ ±1% resistors (0603) |
| R23 | 1 | 1kΩ ±1% resistor (0603) |
| R25, R26, R30, R31 | 4 | 84.5Ω ±1% resistors (0402) |
| R28, R29, R32, R33 | 4 | 124Ω ±1% resistors (0402) |
| R34 | 1 | 110Ω ±1% resistor (0603) |
| R37, R43 | 2 | 392Ω ±1% resistors (0402) |
| R38, R49 | 2 | 49.9Ω ±1% resistors (0402) |
| R40 | 1 | 100kΩ variable resistor Bournes or Digi-Key 3296W-104-ND |
| R41 | 1 | 50kΩ variable resistor Bournes or Digi-Key 3296W-503-ND |
| R42 | 1 | 200kΩ variable resistor Bournes or Digi-Key 3296W-204-ND |
| R44 | 1 | 24.9Ω ±1% resistor (0402) |
| R46 | 1 | 15Ω ±1% resistor (0603) |
| U2 | 1 | MAX3869EHJ (32-pin TQFP-EP) |
| U3 | 1 | MAX495ESA |
| TP2, TP3, TP8, TP10–TP13, TP17, TP18, VCC, GND | 11 | Test points Digi-Key 5000K-ND |
| None | 1 | MAX3869 data sheet |
| None | 1 | MAX3869 EV kit circuit board (rev A) |

Evaluates: MAX3869

MAX3869 Evaluation Kit

Optical Component List

| DESIGNATION | QTY | DESCRIPTION |
|-----------------|-----|---|
| C1–C4, C17, C38 | 6 | 0.01 μ F \pm 10% ceramic capacitors (0402) |
| C5, C10–C13 | 5 | 0.1 μ F \pm 10% ceramic capacitors (0603) |
| C6 | 1 | 1000pF \pm 10% ceramic capacitor (0402) |
| C7 | 1 | 0.056 μ F \pm 10% ceramic capacitor (0603) |
| C8, C35 | 2 | Do not install |
| C16 | 1 | 0.22 μ F \pm 10% ceramic capacitor (0805) |
| C19 | 1 | 10 μ F \pm 20% tantalum (16V) capacitor AVX TAJC106M016 |
| C20, C22, C36 | 3 | 0.01 μ F \pm 10% ceramic capacitors (0603) |
| D1 | 1 | LED Digi-Key P363-ND |
| J1–J4 | 4 | SMA edge-mount connectors EF Johnson 142-0701-801 or Digi-Key J502-ND |
| JU1, JU2 | 2 | 2-pin headers (0.1in center) Digi-Key S1012-36-ND |
| JU1, JU2 | 2 | Shunts Digi-Key S9000-ND |
| L1 | 1 | 1k Ω ferrite bead (0805) Murata BLM21A102S |
| L2 | 1 | 600 Ω ferrite bead (0603) Murata BLM11HA601S |
| L3 | 1 | 0 Ω resistor (0603) |

| DESIGNATION | QTY | DESCRIPTION |
|--|-----|---|
| L4 | 1 | 1.2 μ H Inductor Coilcraft 1008LS-122XKBC |
| L5, L6 | 2 | 600 Ω ferrite beads (0603) Murata BLM11A601S |
| R1, R2 | 2 | 1.5k Ω \pm 1% resistors (0603) |
| R3 | 1 | 1.0k Ω \pm 1% resistor (0603) |
| R6, R7, R10, R11 | 4 | 84.5 Ω \pm 1% resistors (0402) |
| R8, R9, R12, R13 | 4 | 124 Ω \pm 1% resistors (0402) |
| R14 | 1 | 50k Ω variable resistor Bournes or Digi-Key 3296W-503-ND |
| R15 | 1 | 200k Ω variable resistor Bournes or Digi-Key 3296W-204-ND |
| R16 | 1 | 100k Ω variable resistor Bournes or Digi-Key 3296W-104-ND |
| R18 | 1 | 110 Ω \pm 1% resistor (0603) |
| R19, R35 | 2 | 392 Ω \pm 1% resistors (0402) |
| R20 | 1 | 27.4 Ω \pm 1% resistor (0402) |
| R21 | 1 | 49.9 Ω \pm 1% resistor (0402) |
| R27 | 1 | 24.9 Ω \pm 1% resistor (0402) |
| R36 | 1 | 43.2 Ω \pm 1% resistor (0402) |
| TP1, TP4, TP5, TP6, TP14, TP15, TP16, VCC, GND | 9 | Test points Digi-Key 5000K-ND |
| U1 | 1 | MAX3869EHJ (32-pin TQFP-EP) |

Component Suppliers

| SUPPLIER | PHONE | FAX |
|------------|--------------|--------------|
| AVX | 803-946-0690 | 803-626-3123 |
| Coilcraft | 847-639-6400 | 847-639-1469 |
| Digi-Key | 218-681-6674 | 218-681-3380 |
| EF Johnson | 402-474-4800 | 402-474-4858 |
| Murata | 814-237-1431 | 814-238-0490 |
| Zetex | 516-543-7100 | 516-864-7630 |

Quick Start

Electrical Evaluation

In the electrical configuration, an automatic power control (APC) test circuit is included to emulate a semiconductor laser with a monitor photodiode. Monitor diode current is provided by Q2, which is controlled by an operational amplifier (U3). The APC test circuit, consisting of U3 and Q2, applies the simulated monitor diode current (the laser bias current divided by a factor of 100) to the MD pin of the MAX3869. To ensure proper operation in the electrical configuration, set up the evaluation board as follows:

- 1) If data is to be latched, remove the shunt from JU4 to enable the input clock; otherwise, leave the shunt in place.

MAX3869 Evaluation Kit

Evaluates: MAX3869

- 2) Remove the shunt from JU5 to enable the outputs.
Note: When performing the following resistance checks, manually set the ohmmeter to a high range to avoid forward biasing the on-chip ESD protection diodes.
- 3) Adjust R41, the MOD potentiometer, for 10k Ω resistance between pins 1 and 3 (test point 3 and ground).
- 4) Adjust R42, the BIAS potentiometer, for 10k Ω resistance between pins 1 and 3 (test point 2 and ground).
- 5) Adjust R40, the APC potentiometer, for 10k Ω resistance between pins 1 and 3 (test point 8 and ground).
- 6) Apply a differential input signal (max amplitude $\leq 800\text{mV}$ per side) to J7 and J8 (DATA+ and DATA-).
- 7) If the latch is enabled, apply a differential clock signal (max amplitude $\leq 800\text{mV}$ per side) to J5 and J6 (CLK+ and CLK-).
- 8) Attach a high-speed oscilloscope with 50 Ω inputs to J9.
- 9) Power up the board with a +3.3V supply.
- 10) Adjust R42 until the desired laser bias current is achieved.

$$I_{\text{BIAS}} = \frac{V_{\text{TP13}} - V_{\text{TP12}}}{15\Omega}$$

- 11) Adjust R41 until the desired laser modulation current is achieved.

$$I_{\text{MOD}} = \frac{\text{Signal Amplitude (Volts)}}{25\Omega}$$

Optical Evaluation

For optical evaluation of the MAX3869, configure the evaluation kit as follows:

- 1) If data is to be latched, remove the shunt from JU1 to enable the input clock; otherwise, leave the shunt in place.
- 2) Remove the shunt from JU2 to enable the outputs.
- 3) The EV kit is designed to allow connection of a variety of possible laser/monitor diode pin configurations. Connect a TO-header style laser with monitor diode (Figure 1) as follows:

- Keeping its leads as short as possible, connect the laser diode to two of the three pads in the cutout portion on the top (component) side of the PC board. Solder the laser diode cathode to the center pad, and solder the anode to either of the other two pads (they are both connected to V_{CC}).

- Connect the monitor photodiode to two of the five pads on the bottom (solder) side of the PC board, directly below the laser diode pads. Three of these pads (the middle and outside positions) are initially not connected. The other two pads are connected to V_{CC}. Solder the anode and cathode of the monitor photodiode to any two of the three pads that are not connected. Then connect the anode to the MD pin by shorting the corresponding solder jumper (Figure 1). Connect the cathode to V_{CC} by using solder to bridge to an adjacent V_{CC} pad.

Note: When performing resistance checks, manually set the ohmmeter to a high range to avoid forward biasing the on-chip ESD protection diodes.

- 4) Adjust R14, the MOD potentiometer, for maximum resistance between pins 1 and 3 (test point 5 and ground).
- 5) Adjust R15, the BIAS potentiometer, for maximum resistance between pins 1 and 3 (test point 4 and ground).
- 6) Adjust R16, the APC potentiometer, for desired optical power. (Refer to the *Design Procedure* section of the MAX3869 data sheet.)
- 7) Apply a differential input signal ($\leq 800\text{mV}$ per side) to J1 and J2 (DATA+ and DATA-).
- 8) Apply a differential clock signal ($\leq 800\text{mV}$ per side) to J3 and J4 (CLK+ and CLK-).
- 9) Attach the laser diode fiber connector to an optical/electrical converter.
- 10) Power up the board with a +3.3V supply.
- 11) Adjust R15 until the LED, D1, is no longer illuminated. Optical power can be observed on an oscilloscope connected to an optical/electrical converter.
- 12) Adjust R14 until the desired optical amplitude is achieved. Optical amplitude can be observed on an oscilloscope connected to an optical/electrical converter.

MAX3869 Evaluation Kit

Adjustment and Control Descriptions (see Quick Start first)

| COMPONENT | | NAME | FUNCTION |
|-----------|------------|-----------------------|--|
| OPTICAL | ELECTRICAL | | |
| JU1 | JU4 | CLOCK DISABLE | Enables/disables the clock input. Shunt for direct data transmission. Remove shunt to enable clock input. |
| JU2 | JU5 | OUTPUT DISABLE | Enables/disables the output currents. Shunting disables the part. Remove shunt for normal operation. |
| - | J8 | Electrical Output SMA | Electrical Output |
| R14 | R41 | MOD | Adjusts the laser modulation current. |
| R15 | R42 | BIAS | Adjusts the laser bias current. In open-loop mode, R15 or R42 adjusts the laser bias current. In closed-loop operation, R15 or R42 adjusts the maximum laser bias current. |
| R16 | R40 | APC | For closed-loop operation, R16 or R40 adjusts the monitor diode current level. |
| TP1 | TP10 | Fail Indicator | TTL low level indicates a failure in the APC loop. |
| D1 | D3 | Fail Indicator | Refer to the <i>Design</i> section of the MAX3869 data sheet. Set APC current, then increase bias current until LED goes off (LED is illuminated when the APC loop is open and off when the APC loop is closed). |

Evaluates: MAX3869

MAX3869 Evaluation Kit

Evaluates: MAX3869

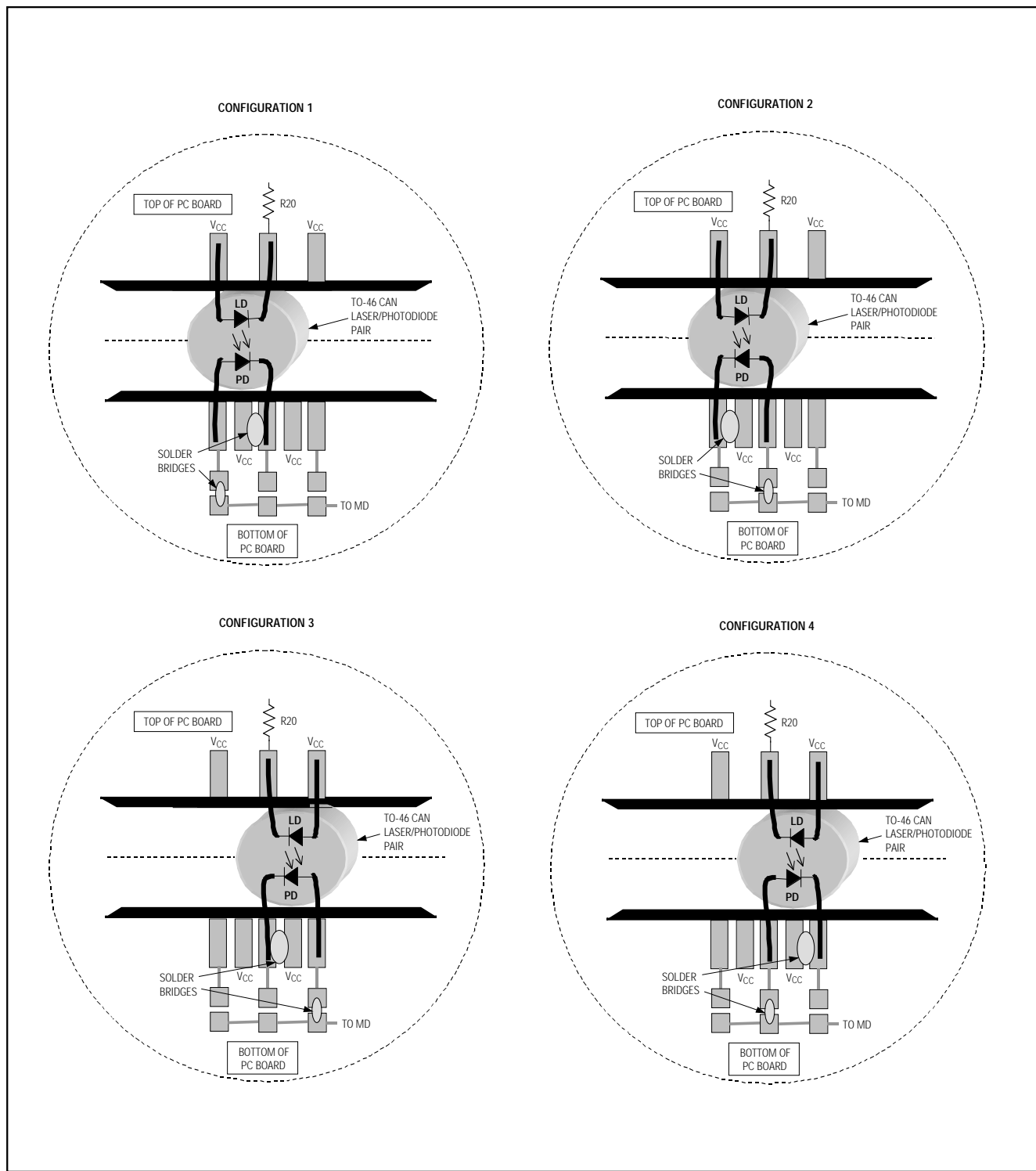

Figure 1. Attachment of Laser Diode/Monitor Diode to MAX3869 EV Kit

MAX3869 Evaluation Kit

Evaluates: MAX3869

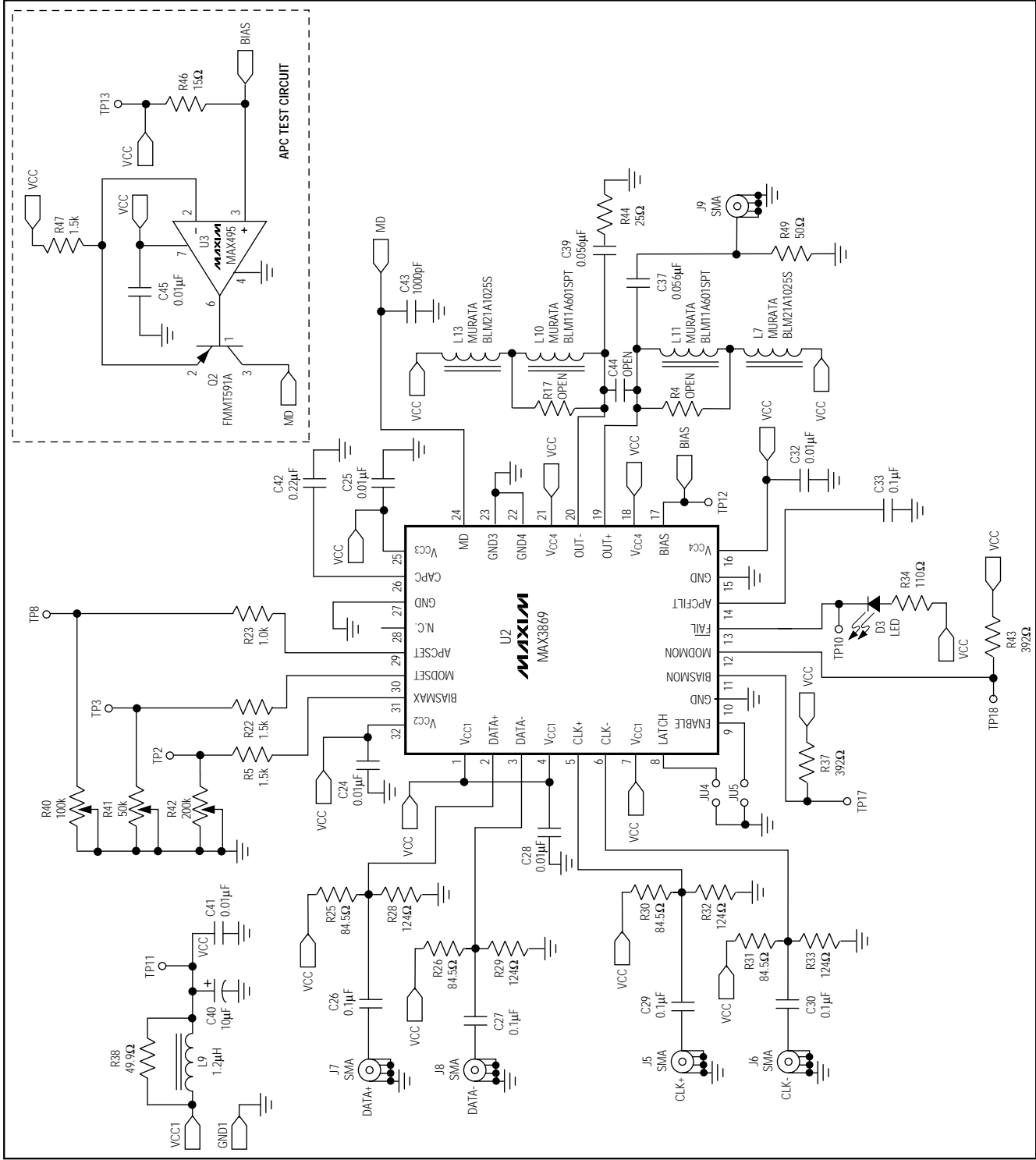

Figure 2. MAX3869 EV Kit Schematic—Electrical Configuration

MAX3869 Evaluation Kit

Evaluates: MAX3869

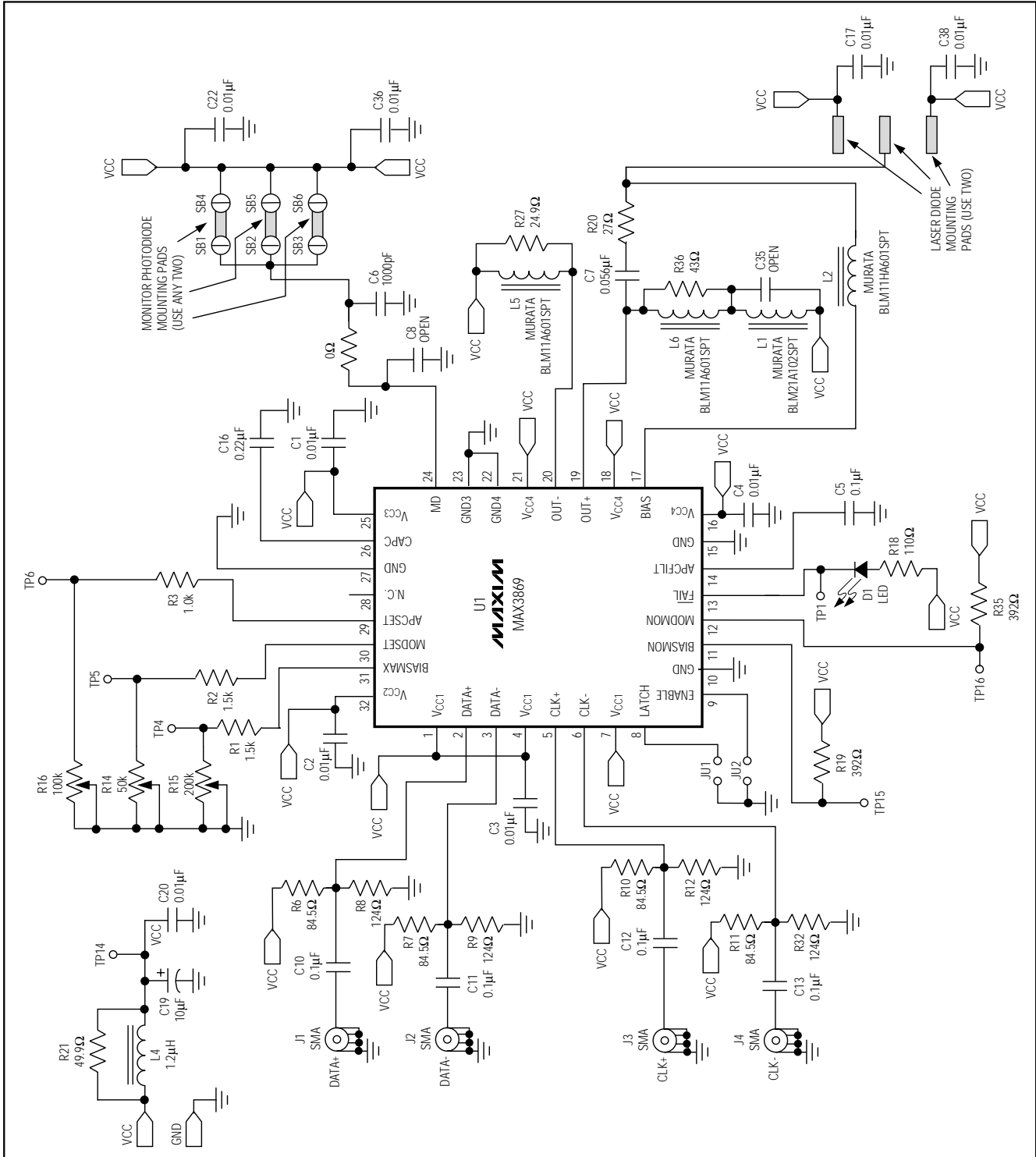

Figure 3. MAX3869 EV Kit Schematic—Optical Configuration

MAX3869 Evaluation Kit

Evaluates: MAX3869

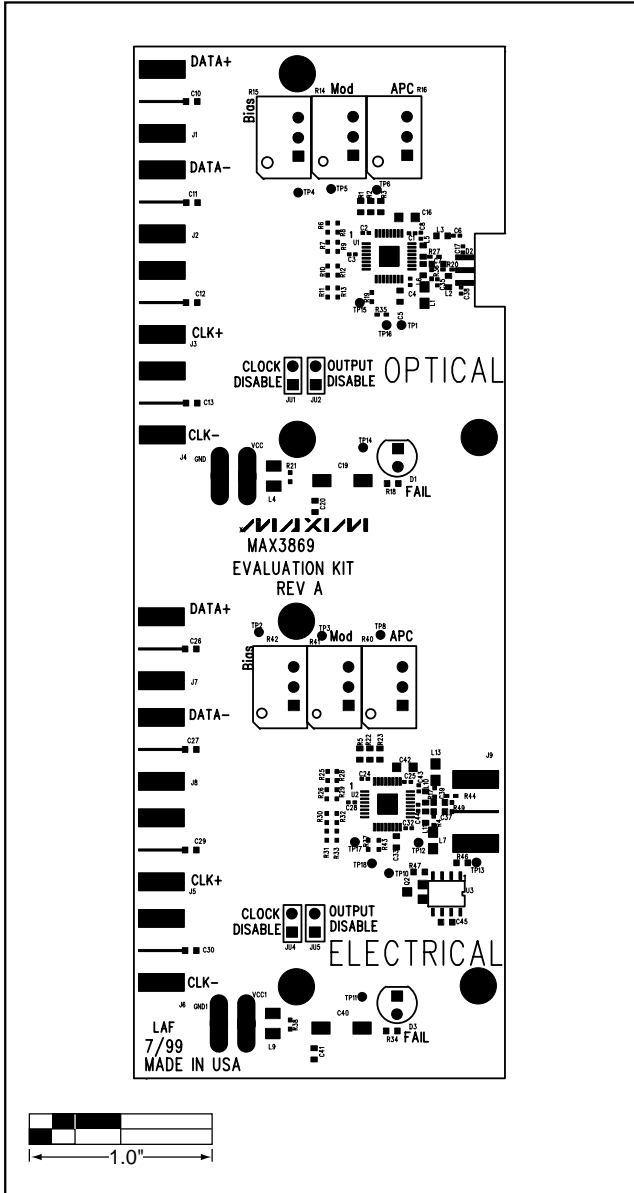

Figure 4. MAX3869 EV Kit Component Placement Guide—Component Side

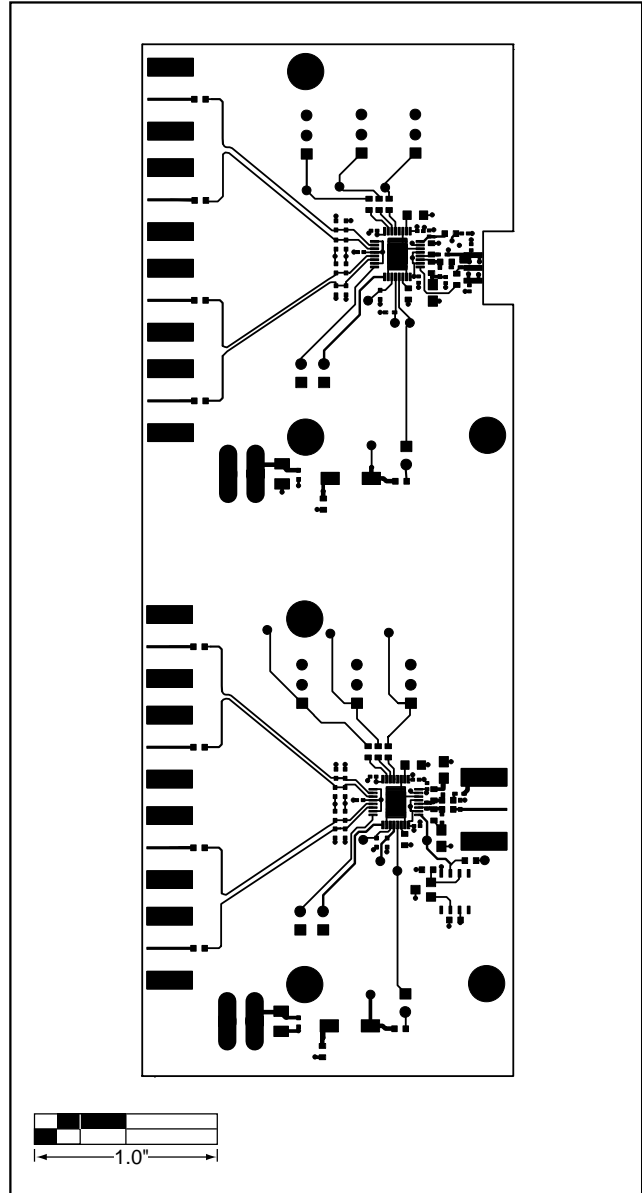

Figure 5. MAX3869 EV Kit PC Board Layout—Component Side

MAX3869 Evaluation Kit

Evaluates: MAX3869

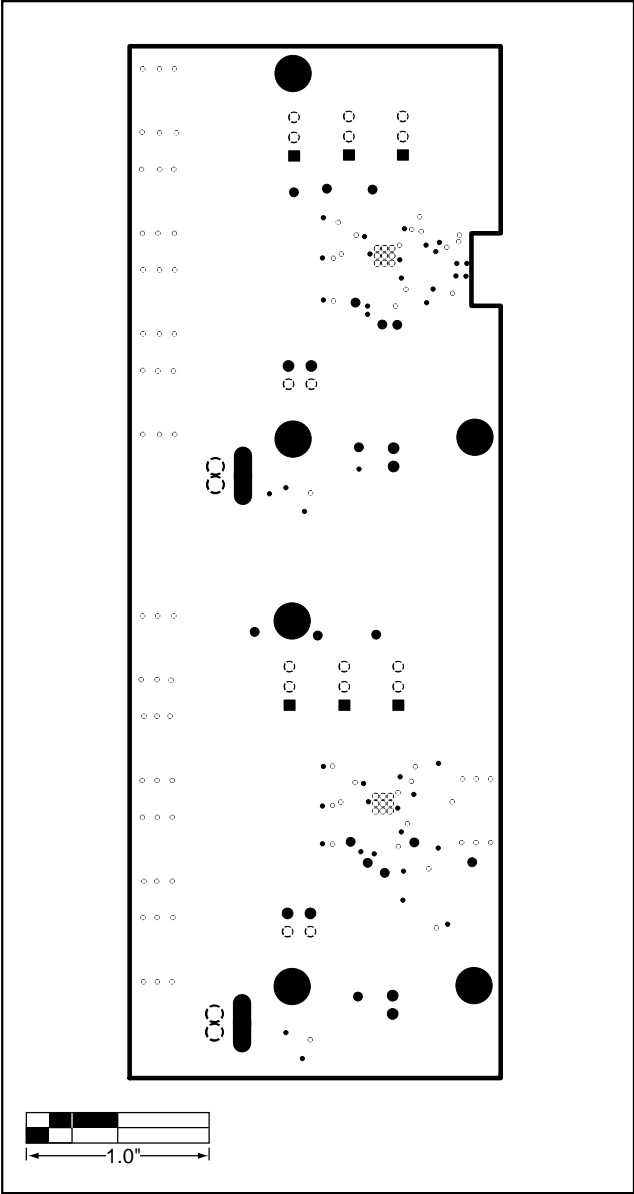

Figure 6. MAX3869 EV Kit PC Board Layout—Ground Plane

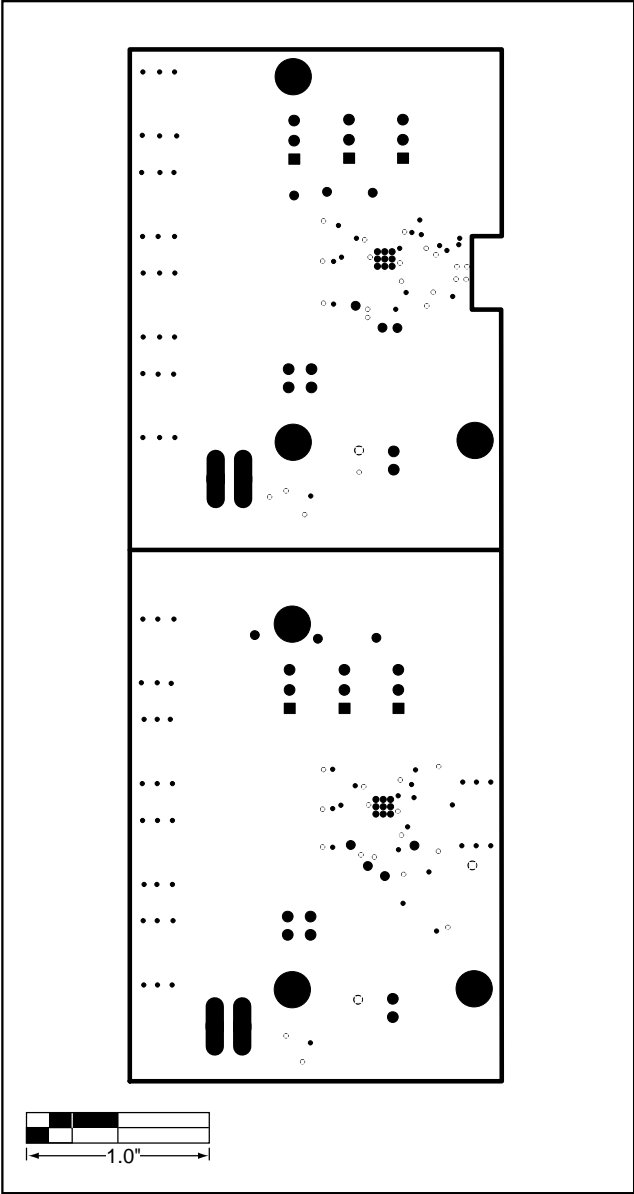

Figure 7. MAX3869 EV Kit PC Board Layout—Power Plane

MAX3869 Evaluation Kit

Evaluates: MAX3869

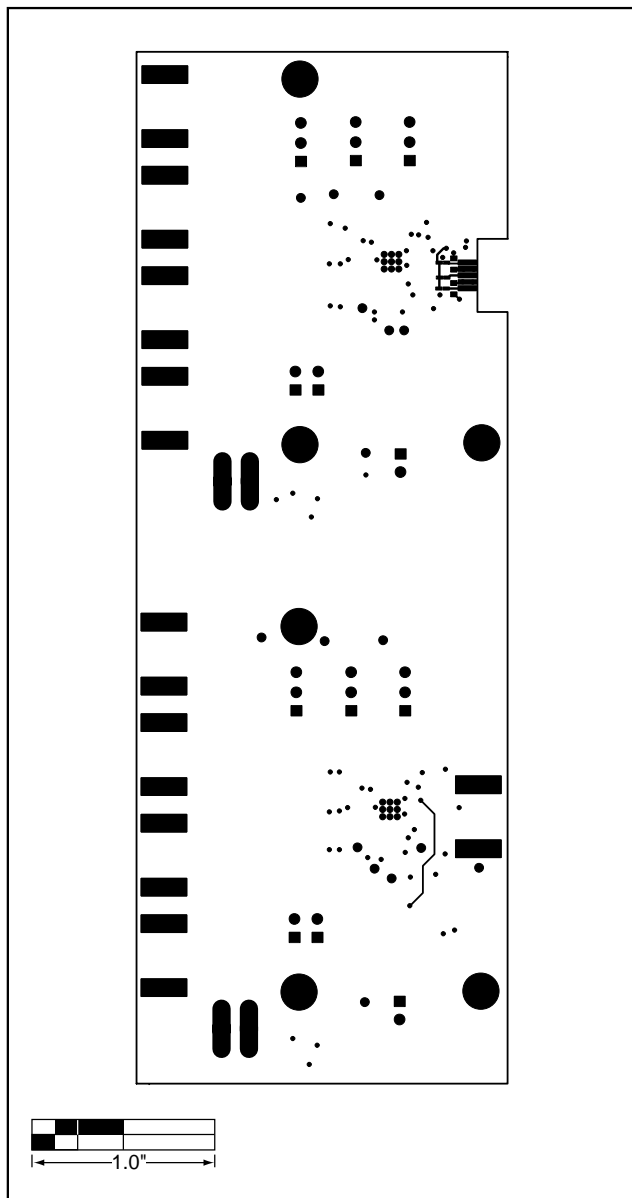

Figure 8. MAX3869 EV Kit PC Board Layout—Solder Side

MAX3869 Evaluation Kit

NOTES

Evaluates: MAX3869

MAX3869 Evaluation Kit

Evaluates: MAX3869

NOTES

Maxim makes no warranty, representation or guarantee regarding the suitability of its products for any particular purpose, nor does Maxim assume any liability arising out of the application or use of any product or circuit and specifically disclaims any and all liability, including without limitation consequential or incidental damages. "Typical" parameters can and do vary in different applications. All operating parameters, including "typicals" must be validated for each customer application by customer's technical experts. Maxim products are not designed, intended or authorized for use as components in systems intended for surgical implant into the body, or other applications intended to support or sustain life, or for any other application in which the failure of the Maxim product could create a situation where personal injury or death may occur.

12 _____ Maxim Integrated Products, 120 San Gabriel Drive, Sunnyvale, CA 94086 408-737-7600